

A description is given of the design of a roll-type mold for the production of metal strip. The mold is cooled through the use of an evaporation-condensation cycle. The method described for the design of the structural elements of the mold is based on ensuring the required transport of the working fluid to the thermally loaded zone. The characteristics of strips of aluminum alloys cast on the mold are given.

Both rapidly rotating roll-type molds (centripetal acceleration on the ring  $a$  greater than  $5g$ ) are used to produce metal of the same type ( $a < 5g$ ) are used to produce metal strip, depending on its thickness. The frequency of rotation of the mold determines the method of its cooling. Centrifugal heat pipes [1] have been used to cool rapidly-rotating molds, while slowly rotating molds are usually cooled by water which washes over the inside part of the working ring [2]. However, the high thermal loads and fluctuation of the stability of cooling cause local boiling and drying on the inside surface of the roll. This in turn leads to its washing by a two-phase flow, discontinuous heat transfer, and a consequent deterioration in the quality of the finished product. Some of the strip must be rejected to variations in its thickness.

A more optimum approach is to cool the mold as a result of a phase transformation (evaporation, boiling) involving liquid in a capillary-porous body. In this case, heat transfer is intensified because it takes place on developed surfaces. The extension of the working fluid by the forces associated with surface tension over the entire capillary-porous body helps to make heat transfer uniform across the mold and fill the dried regions which develop. By appropriately choosing the characteristics of the capillary-porous body (material, porosity, permeability, pore size), it is possible to ensure the necessary ratio of the incoming heat flux to the volume of capillary-enveloped fluid in the working section. These factors, characterizing the phase transformation in the capillary-porous body, help to make a quality product.

To make thick metal sheets ( $\delta$  up to 3 mm), we developed an original device based on the use of porous cooling with a closed evaporation-condensation cycle [3].

The device (Fig. 1) includes a rotating roll-mold 1 with a capillary-porous layer of material 2, a system to supply the working fluid which includes a storage tank 3 and a branch pipe 4 with a porous elastic packet 5, a condenser 6 with a liquid heat exchanger 7 and fins 8, and a melt supply system 9. The device is equipped with a clamping roller 10 which keeps the strip in contact with the mold. Upon rotation of the periphery of the roll surface, a layer of liquid metal is entrained from the body of the superheated melt. The heat given off during cooling and solidification of the melt is absorbed due to boiling and evaporation of the working fluid in the capillary-porous layer. The vapors which are formed tend to move toward the region of lowest pressure - toward the condenser, which is cooled by the liquid heat exchanger. Under the influence of gravitational forces, the film flows into the tank. The liquid subsequently flows along a channel into the branch pipe, where it is suctioned into the porous elastic packet. The packet transports the liquid to the capillary-porous layer of the roll-mold. A closed evaporation-condensation cycle is thus created. This cycle exists only in the case of equilibrium of the liquid with its vapor, i.e., in the absence of noncondensing gases. To ensure satisfaction of this condition, the working cavity of the device was made hermetic.

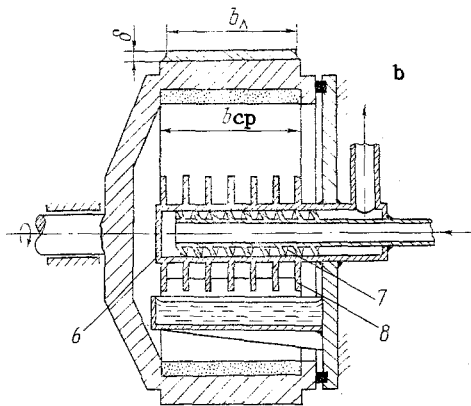
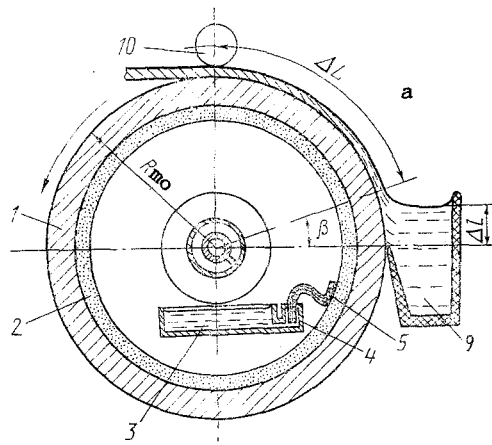

Fig. 1

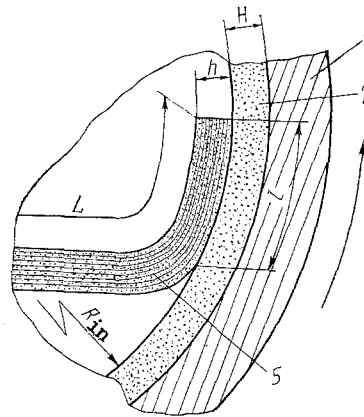

Fig. 2

Fig. 1. Sketch of device for producing sheet metal in strip form: a) frontal view; b) side view.

Fig. 2. Site of contact of porous elastic element with capillary-porous layer of roll-mold.

In designing the device, the main problem was determining the dimensions and characteristics of its elements so as to ensure the necessary translational velocity for the working fluid as it moves from the condenser to the thermally loaded zone. The method of calculation used here included the following steps:

- 1) determination of the total thermal load and the maximum heat flux;
- 2) selection of the working fluid (coolant);
- 3) determination of the mass flow rate of the coolant from the condenser to the evaporator so as to ensure removal of the thermal load;
- 4) determination of the dimensions and characteristics of the capillary-porous layer on the basis of the inclusion of the required volume of fluid in it;
- 5) determination of the dimensions and characteristics of the porous elastic packet to ensure its transport of the required quantity of fluid;
- 6) determination of the dimensions of the condenser so as to ensure the requisite condensation rate.

The following assumptions were made in the design of the device:

- 1) the liquid-metal strip is held on the periphery of the mold by friction and surface tension;
- 2) strip is cooled only as a result of contact heat transfer.

The initial parameters for the calculations were the diameter of the roll, the maximum thickness and required width of the strip, the thermophysical properties of the alloy being

teemed and of the roll material, teeming temperature, and the temperature at which the strip leaving the roll hardens.

To obtain strip of thickness  $\delta$ , it is necessary to ensure the following frequency of rotation of the roll-mold [4]

$$n = \sqrt{\frac{f\sigma_m \Delta l \cos \theta_m - g \Delta l \rho_m \delta_m (\cos \beta - f \sin \beta)}{2\pi^2 R_{mo} \rho_m \delta_m^2 (R_{mo} + 2f \Delta l)}}.$$

Then the mass productivity of the device

$$M = 2\pi R_{mo} n \delta_m b_m \rho_m.$$

The thermal load on the mold includes the heat liberated during the cooling of the melt to the temperature at which solidification begins, the heat of crystallization, and the heat liberated during the cooling of the solidified strip up to the moment of its removal from the roll:

$$Q = M (C_m \Delta T_{s.m} + r + C_s \Delta T_{co}).$$

Accordingly, the total time an elementary section of the strip is on the mold is

$$\tau = \tau_{s.m} + \tau_{mo} + \tau_{co}.$$

The values of  $\tau_{s.m}$  and  $\tau_{co}$  are found as the ratio of  $\Delta T_{s.m}$  and  $\Delta T_{co}$  to the rates of cooling of the melt and the solidified strip [4]. The time of crystallization is determined by the law governing the release of the latent heat of crystallization and the condition for heat balance between the melt and the substrate [5].

The total length of arc of the mold on which solidification, crystallization, and cooling take place is:

$$\Delta L = 2\pi R_{mo} n (\tau_{s.m} + \tau_{mo} + \tau_{co}).$$

The heat flux on each section:

$$q_{s.m} = \frac{MC_m \Delta T_{s.m}}{2\pi R_{mo} n \tau_{s.m} \delta_m};$$

$$q_{mo} = \frac{Mr}{\pi R_{mo} n \tau_{mo} (\delta_m + \delta_s)};$$

$$q_{co} = \frac{MC_s \Delta T_{co}}{2\pi R_{mo} n \tau_{co} \delta_s}.$$

An analysis of the maximum heat flux makes it possible to select the coolant that can remove the thermal load without the creation of a heat-transfer crisis during boiling.

There are currently no sufficiently proven relations to determine the critical heat fluxes during boiling in capillary-porous bodies under the influence of centrifugal forces. The formula for boiling in a large volume [6] is usually used:

$$q_{crt} = \frac{\pi}{24} \rho_i r^* \rho_v \left[ \frac{\sigma (\rho_l - \rho_v)}{\rho_v} \right]^{0.25} \left[ \frac{\rho_v}{\rho_l + \rho_v} \right]^{0.5} \left( \frac{a}{g} \right)^n.$$

The last term of this equation accounts for the effect of centripetal acceleration [7].

At

$$1 < \frac{a}{g} < 10 \quad n = 0,15.$$

The quantity of coolant which must be evaporated per unit time to remove the thermal load:

$$\dot{m} = \frac{Q}{r^*} K = \frac{2\pi R_{mc} n \delta_m b_m \rho_m (C_m \Delta T_{s.m} + r + C_s \Delta T_{co}) K}{r^*}. \quad (1)$$

The volume of coolant evaporated during the time  $\tau$ :

$$W = \frac{m\tau}{\rho_{\ell}}$$

The thickness of the capillary-porous layer is found on the basis of the following considerations (Fig. 2):

a) on the one hand, a volume of fluid  $W$  should be located on its inside part, which is of the length  $2\pi R_{in}n\tau$ :

$$H_1 = \frac{W}{2\pi R_{in} n \tau b_{cp} \Pi_{cp}};$$

b) on the other hand, the capillary-porous layer should ensure the transport of the required quantity of coolant in the radial direction:

$$H_2 = \frac{2\Pi_{pmo} \Delta P b_{cp} \pi R_{in} n \tau}{\mu_{\ell} n}$$

Removal of the thermal load is assured when  $H_1 \leq H_2$ . This condition can be satisfied by appropriately selecting the characteristics of the capillary-porous layer, i.e., its porosity and permeability.

The length of the contacting section of the porous elastic packet is determined on the basis of the condition for filling of the capillary-porous layer with fluid during rotation of the mold at the prescribed velocity. The time of filling of this layer when the coolant is absorbed into the material in the radial direction

$$\tau = \frac{h^2 \mu_{\ell} \Pi}{\Pi_{cp} \Delta P}$$

During this time, there should be contact with a part of the packet of the length

$$\tau = \frac{l}{2\pi R_{in} n}$$

By simultaneously solving these equations, we find the length of the contacting part of the packet:

$$l = \frac{2\pi R_{in} n \mu_{\ell} h^2 \Pi}{\Pi_{cp} \Delta P}$$

The dimensions of the packet are calculated on the basis of the condition that ensures transport of the necessary amount of fluid  $\dot{m}$ .

Considering that

$$\dot{m} = \frac{\Pi_{cp} \rho_{\ell} \Delta P b_{cp} h}{\mu_{\ell} L}, \quad (2)$$

we can use Eqs. (1) and (2) to find the ratio of the thickness of the packet to its overall length:

$$\frac{h}{L} = \frac{2\pi R_{mo} n \delta_m b_m \rho_m (C_m \Delta T + r + C_s \Delta T_{co}) \mu_{\ell} K}{\Pi_{cp} \Delta P r^* b_{cp}}$$

During the filling of the packet and the capillary-porous layer, the fluid will move under the influence of the surface tension which develops in each element. Transfer of the fluid from one element to another takes place when the capillary potential of the fluid in the layer is higher than in the packet.

During a steady-state process, the coolant is transported due to the difference in capillary pressure over the entire system. Considering that the meniscus is planar in the branch pipe ( $\theta_{\ell} = 90^\circ$ ) and has the maximum curvature in the end ( $\theta_{\ell} = 0^\circ$ ), we obtain the following expression for the capillary pressure that will transport the coolant:

$$\Delta P = \frac{2\sigma}{R_{cp}}$$

To determine the dimensions of the condenser, it is necessary to know the temperature drop over the device:

$$\Sigma \Delta T = \Delta T_1 + \Delta T_2 + \Delta T_3 + \Delta T_4 + \Delta T_5 + \Delta T_6 + \Delta T_7 + \Delta T_8,$$

where  $\Delta T_1$  is the temperature drop across the contact between the liquid-metal strip and the periphery of the mold;  $\Delta T_2$  is the temperature drop over the ring part of the mold in the radial direction;  $\Delta T_3$  is the temperature drop between the inside surface of the ring and the capillary-porous layer;  $\Delta T_4$  is the temperature drop over the capillary-porous layer;  $\Delta T_5$  is the temperature drop in the vapor;  $\Delta T_6$  is the temperature drop between the vapor and the wall of the condenser;  $\Delta T_7$  is the temperature drop over the body of the condenser;  $\Delta T_8$  is the temperature drop between the inside wall of the condenser and the cooling which takes place in the liquid heat exchanger.

The temperature drops  $\Delta T_1$ - $\Delta T_4$  were calculated by the simultaneous solution of the equations of heat conduction and contact heat transfer. The temperature drop over the vapor  $\Delta T_5$  is usually ignored, due to its smallness. The coefficient of contact heat transfer between the strip and the mold was determined as the ratio of the thermal conductivity of air to the height of the microroughnesses on the outside surface of the roll. The study [8] offered recommendations on calculating the coefficient of heat transfer between a mold and a capillary-porous layer, as well as the thermal conductivity of the layer.

The heat-transfer coefficient and the temperature drop  $\Delta T_8$  between the wall and the cooled fluid were calculated in relation to the flow regime and velocity from the equation proposed by Mikheev [9]. The pressure drop over the body of the condenser (and the liquid heat exchanger simultaneously)  $\Delta T_7$  was found from the heat conduction equation. The difference between the temperature of the vapor and the temperature of the condenser wall was the quantity  $\Delta T_6$ . We used the value of this temperature drop and size of the body together with the Nusselt equation to determine the heat-transfer coefficient during condensation  $\alpha_{cn}$ . We then checked for satisfaction of the relation

$$\frac{Q}{A_{cn}} \leq \alpha_{cn} \Delta T_6.$$

If this relation is not satisfied, then the condenser should have fins. The number and dimensions of the fins are chosen on the basis of design considerations. The heat-transfer coefficient during condensation is determined for the fins. This is followed by calculation of the corrected heat-transfer coefficient  $\alpha_{cd}$  and a check for satisfaction of the relation

$$\frac{Q}{A_{wa} + A_{cn}} \leq \alpha_{cd} \Delta T_6.$$

The method described above was used to design and make an experimental unit to produce metal strip of aluminum alloys. The roll-mold has a diameter of 0.6 m and a width of 0.15 m. The frequency of rotation varies from 0.8 to 2.67  $\text{sec}^{-1}$ . The thickness of the strip is within the range  $(0.8-2.5) \cdot 10^{-3}$  m, depending on the frequency of rotation and length of the zone of contact between the roll's periphery and the melt. The productivity of the device attained its maximum value ( $M = 1.9$  tons/h) at  $n = 2.67 \text{ sec}^{-1}$ .

Due to an intensification of heat transfer and the steps taken to make it uniform, the product obtained in tests had a fine-grained structure. This in turn resulted in a 20-30% increase in tensile strength and a 10-20% increase in relative elongation. The scheme devised for the cooling of the mold has made it possible to better organize the teeming operation and improve the quality of the resulting strip. Rejects have been reduced by 15%.

#### NOTATION

A, area,  $\text{m}^2$ ; a, centripetal acceleration,  $\text{m}/\text{sec}^2$ ; b, width, m; C, heat capacity of the liquid-metal strip,  $\text{J}/(\text{kg}\cdot\text{K})$ ; f, friction; g, gravitational acceleration,  $\text{m}/\text{sec}^2$ ; H, thickness of the capillary-porous layer, m; h, thickness of the porous packet, m; K, coefficient accounting for loss of mass due to boiling in the capillary-porous layer; L, total length of the porous packet, m;  $\Delta L$ , length of the segment of the mold on which cooling of the strip takes place, m;  $\ell$ , length of the contacting section of the porous packet, m;  $\Delta \ell$ , free height of the molten layer, m; M, productivity,  $\text{kg}/\text{sec}$ ;  $\dot{m}$ , mass flow rate of the coolant,  $\text{kg}/\text{sec}$ ; n, frequency of rotation,  $\text{sec}^{-1}$ ;  $\Delta P$ , difference in surface tension,  $\text{N}/\text{m}^2$ ; Q, heat flux, W;

q, heat flux density, W/m<sup>2</sup>; R, radius, m; r, latent heat of crystallization, J/kg; r\*, latent heat of vaporization, J/kg; ΔT, superheat, K; W, volume, m<sup>3</sup>; Π, porosity; Pm, permeability, m<sup>2</sup>; α, heat-transfer coefficient, W/(m<sup>2</sup>·K); β, angle of inclination of the pouring-channel system, deg; δ, thickness, m; θ, contact angle, deg; μ, viscosity, N·sec/m<sup>2</sup>; σ, surface tension, N/m; ρ, density, kg/m<sup>3</sup>; τ, time, sec. Indices: in, internal; ℓ, liquid; cn, condenser; cp, capillary-porous; mo, mold (crystallization); crt, critical; s, strip; co, cooling; v, vapor; cd, corrected; s.m, superheat of melt; m, melt; fi, fin; wa, wall.

#### LITERATURE CITED

1. "Method of cooling rotating rolls," Japanese Patent Application No. 61-43148, 1982. Izobr. Stran Mira, No. 9 (1986).
2. A. I. Veinik, Permanent Mold [in Russian], Minsk (1972).
3. "Device for the production of metal strip," Inventor's Cert. No. 1,452,649 SSSR: MKI B 22 D 11/06.
4. A. N. Abramenko, A. S. Kalinichenko, M. A. Antonevich, and É. D. Sychikov, Inzh.-Fiz. Zh., 55, No. 1, 117-122 (1988).
5. É. A. Gurvich, N. P. Zhmakin, A. S. Kalinichenko, et al., Metallurgy, Minsk (1989), pp. 88-90.
6. L. Tong, Heat Transfer in Boiling and Two-Phase Flow [Russian translation], Moscow (1960).
7. J. M. Adams, A Study of the Critical Heat Flux in Accelerating Pool Boiling System, NSF-19697, Univ. Washington (1962).
8. L. L. Vasil'ev, V. G. Kiselev, Yu. N. Matveev, and F. F. Molodkin, Heat Exchangers Based on Heat Pipes [in Russian], Minsk (1987).
9. M. A. Mikheev and I. M. Mikheeva, Principles of Heat Transfer [in Russian], Moscow (1973).

#### POSSIBILITY OF EXPANDING THE STABILITY DOMAIN OF THE FIBER DRAWING PROCESS

V. L. Kolpashchikov, Yu. I. Lanin, O. G. Martynenko,  
and A. I. Shnip

UDC 532.51:532.522

It is shown that the fiber drawing process in the constant viscosity mode becomes more stable when the initial jet rate depends on the tensile force. In the particular case of a directly proportional dependence, the drawing process is stable for any values of the necking factor. Stability patterns of the process and amplitude-frequency characteristics are represented.

It is known that the fiber drawing process becomes unstable when the velocity coefficient (the ratio between the drawing velocity and the supply velocity) exceeds a certain critical value. Thus, the critical value of the rate coefficient is a quantity of the order of 20 [1, 2] for drawing in a constant viscosity mode. Because of buckling the drawing process goes over into a self-oscillatory mode for which the fiber output parameter can differ substantially from the given value. This phenomenon, called "drawing resonance" was detected both theoretically and experimentally [3-5]. However, processes realizable stably for significantly higher velocity ratios than that mentioned above are known in many technical applications. This turns out to be possible because of the action of a number of stabilizing factors in real processes. One such factor is the nonconstancy of viscosity along the jet due to the spatial inhomogeneity of its temperature. Another such factor, although

---

A. V. Lykov Institute of Heat and Mass Transfer. Academy of Sciences of the Belorussian SSR, Minsk. Translated from Inzhenerno-Fizicheskii Zhurnal, Vol. 59, No. 1, pp. 26-34, July, 1990. Original article submitted January 30, 1989.